

NetworkCam

MZ-3333-01

User's Manual



IV&C

Industrial Video and Control

Package Contents

Network Camera



Power adapter



Installation

Hardware Installation

Please verify that your product package contains all the accessories listed in the foregoing Package Contents. Depending on the user's application, an Ethernet cable may be needed. The Ethernet cable should meet the specs of UTP Category 5 and not exceed 100 meters in length.

 Connect the power adapter jack to the Network Camera before plugging in to the power socket. This will reduce the risk of accidental electric shock.

Upon powering up, the device runs through a self-test procedure and the LEDs will blink between green and red for a few times. If self-test passes, the green LED will shut off while the red LED is constantly on and the Network Camera will be on stand-by and ready for software installation. If self-test fails the red LED will blink several times. Refer to Appendix A for troubleshooting.

Ethernet Connection

Make sure the Ethernet is firmly connected to a switch hub; then, plug in the power adapter. If the LED turns out to be steady green after self-test, go to next paragraph "Software Installation".

The Network Camera provides a general I/O terminal block with one digital input and one relay switch for device control. Pin 3 and Pin 4 can be connected to an external sensor device and the state of voltage can be monitored from the initial state 'LOW'. The relay switches Pin 1 and Pin 2 can be used to turn on or off an external device.

⚠ Consult with the dealer of the peripherals for correct installation.

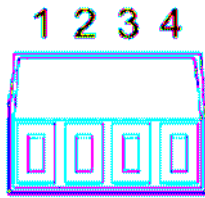

- | | | |
|---|-----------|---|
| 1 | SW_NOPEN | OUTPUT (Max. 1A, 24VDC or 0.5A, 125VAC) |
| 2 | SW_COMMON | OUTPUT (open from SW_OPEN at initial state)
(close with SW_OPEN when set DO to ON) |
| 3 | DI+ | INPUT (Max. 50mA, 12VDC) |
| 4 | DI- | INPUT (Initial state of DI is low) |

Mount the Camera

Use the supplied wrench to remove the dome cover

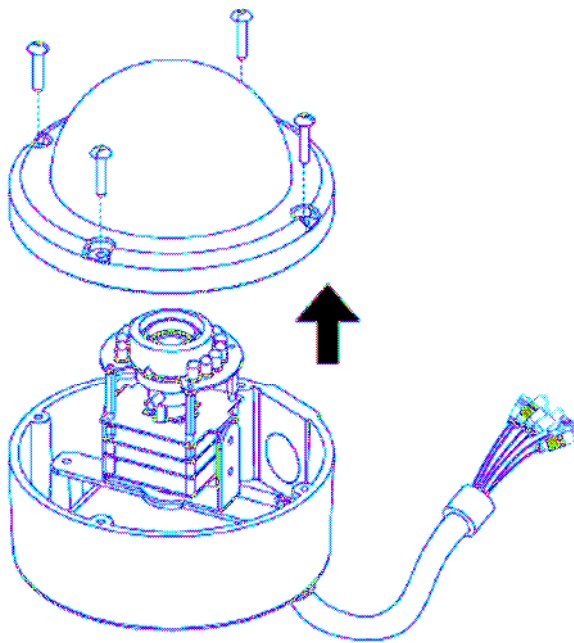

Fix the camera to the wall/ceiling with four supplied screws

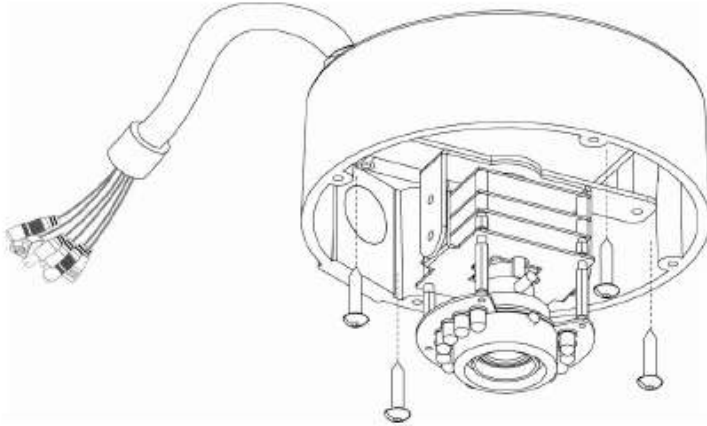

Make connections

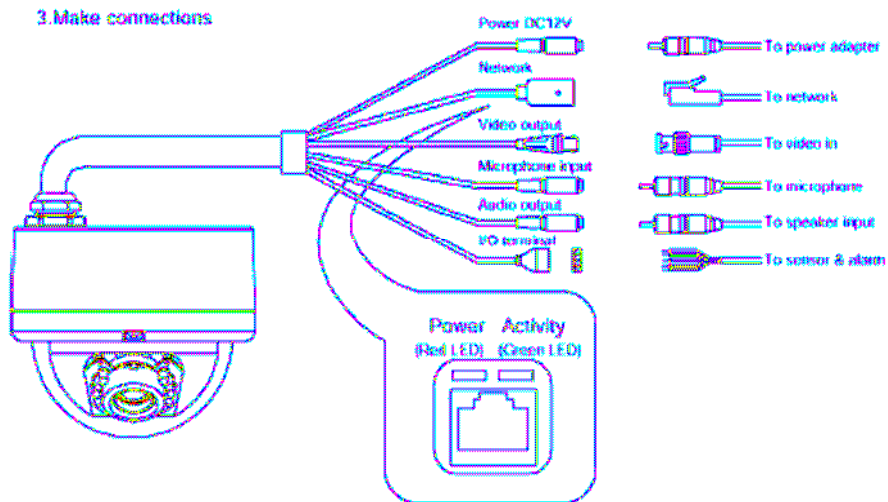

Use the pan/tilt mechanism to set the camera to a proper position

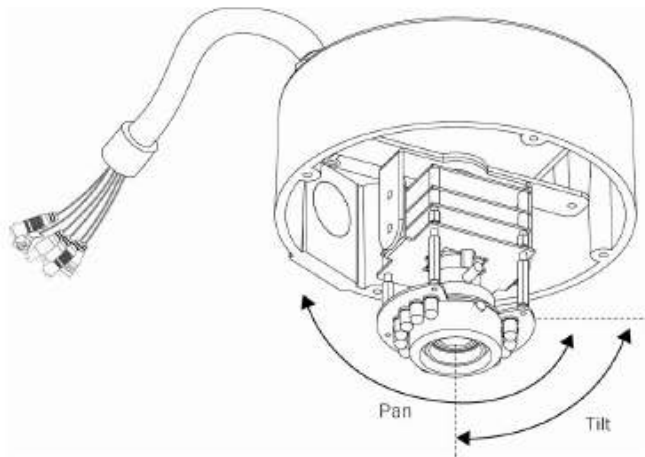

Attach the dome cover back to the camera

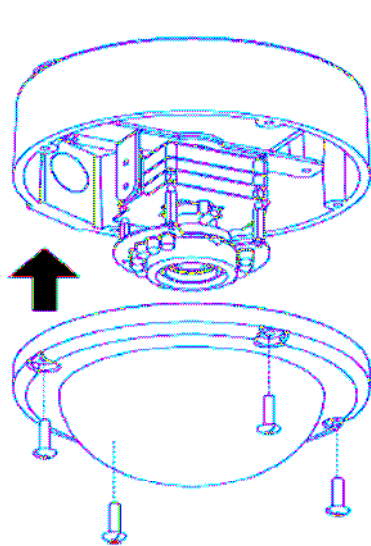

Initial Access to the Network Camera

Installing Plug-in

For the initial access to the Network Camera in Windows, the web browser may prompt for permission to install a new plug-in for the Network Camera after a period of time of downloading. Permission request depends on the Internet security settings of the user's PC or notebook. If the highest security level is set, the computer may prohibit any installation and execution attempt. This plug-in has been registered for certificate and is used to display the video in the browser. Users may click on to proceed. If the web browser does not allow the user to continue to install, check the Internet security option and lower the security levels or contact your IT or networking supervisor for help.

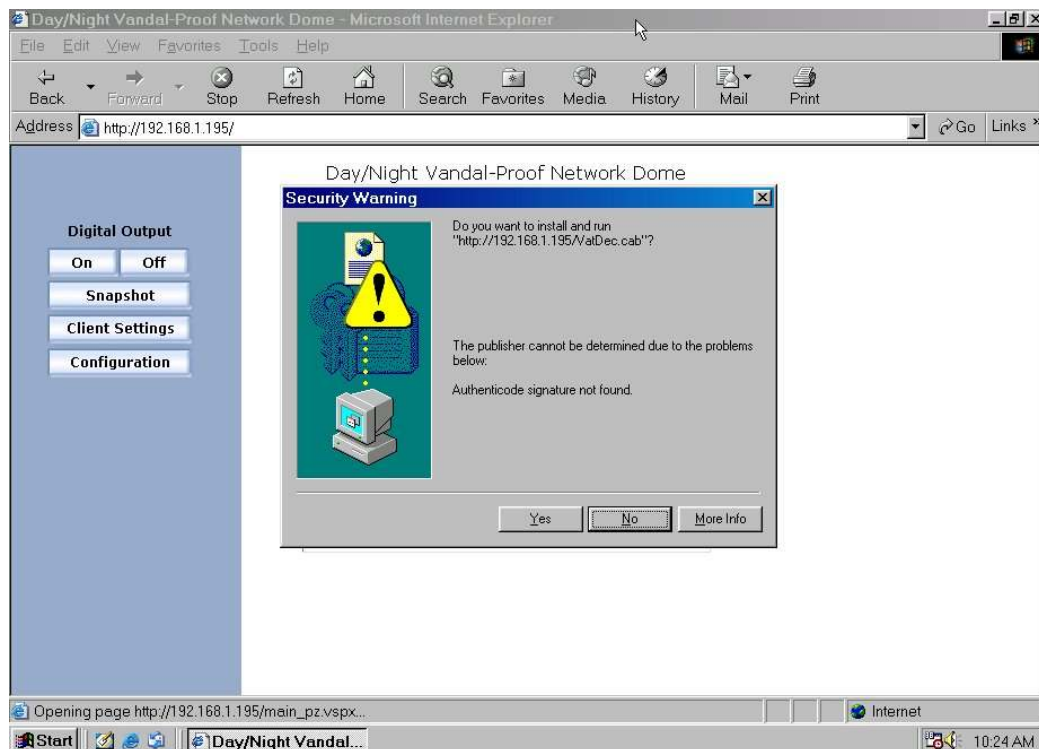

Add Password to Prevent Unauthorized Access

The default Administrator's password is blank and the Network Camera initially will not ask for any password. The Administrator should immediately implement a new password as a matter of prudent security practice. Once the Administrator's password is saved, the Network Camera will ask for the user's name and password before each access. The Administrator can set up a maximum of twenty (20) user accounts. Each user can access the Network Camera except to perform system configuration. Some critical functions are exclusive for the Administrator, such as system configuration, user administration, and software upgrades. The user name for the Administrator is permanently assigned as "root". Once the password is changed, the browser will display an authentication window to ask for the new password. **Once the password is set, there is no provision to recover the Administrator's password. The only option is to restore to the original factory default settings.**

Definitions in Configuration

Only the Administrator can access system configuration. Each category in the left column will be explained in the following pages. The bold texts are the specific phrases on the Option pages. The Administrator may type the URL below the figure to directly enter the frame page of configuration. If the Administrator also wants to set certain options through the URL, read the reference appendix for details.

The screenshot displays a web-based configuration interface. At the top right, the word "Configuration" is displayed in a blue header. On the left side, there is a vertical navigation menu with the following items: Home, System (selected), Security, Network, DDNS & UPnP, Mail & FTP, Video, Audio, Motion detection, Application, View log file, View parameters, and Factory default. Below the menu, the text "Version : 0100a" is visible. The main content area is titled "> System" and contains the following settings:

- Host name :** A text input field containing "Day/Night Vandal-Proof Network Dome".
- Turn off the LED indicator
- Keep current date and time**
- Sync with computer time**
 - PC date: [yyyy/mm/dd]
 - PC time: [hh:mm:ss]
- Manual**
 - Date: [yyyy/mm/dd]
 - Time: [hh:mm:ss]
- Automatic**
 - NTP server:
 - Time zone: (dropdown menu)
 - Update interval: (dropdown menu)

A "Save" button is located at the bottom of the configuration options.

System Parameters

"Host name" The text displays the title at the top of the main page.

"Turn off the LED indicator" Check this option to shut off the LED on the Ethernet connector. It can prevent the camera's operation being noticed.

"Keep current date and time" Click on this to reserve the current date and time of the Network Camera. An internal real-time clock maintains the date and time even when the power of the system is turned off.

"Sync with computer time" Synchronize the date and time of the Network Camera with the local computer. The read-only date and time of PC is displayed as updated.

"Manual" Adjust the date and time according to what is entered by the Administrator. Notice the format in the related fields while doing the entry.

"Automatic" Synchronize with the NTP server over the Internet whenever the Network Camera starts up. It will fail if the assigned time-server cannot be reached.

"NTP server" Assign the IP address or domain name of the time-server. Leaving the text box blank connects the Network Camera to the default time-servers.

"Time zone" Adjust the time with that of the time-servers for local settings.

"Update interval" Select hourly, daily, weekly, or monthly update with the time on the NTP server.

Remember to click on  to immediately validate the changes. Otherwise, the correct time will not be synchronized.

Network Settings

Any changes made on this page will need to restart the system in order to validate the changes. Make sure every field is entered correctly before clicking on **Save**.

"Get IP address automatically" & "Use fixed IP address"

The default status is "**Get IP address automatically**". This can be tedious having to perform software installation whenever the Network Camera starts. Therefore, once the network settings, especially the IP address, have been entered correctly, select "**Use fixed IP address**" then the Network Camera will skip installation at the next boot. The Network Camera can automatically restart and operate normally after a power outage. Users can run IP installer to check the IP address assigned to the Network Camera if the IP address is forgotten or using the UPnP function provided by the Network Camera (MS Windows XP provides UPnP function at **My Network Place**). As for how to get IP address automatically, please refer to the section of **Error! Reference source not found.**

General

"**IP address**" This is necessary for network identification.

"**Subnet mask**" It is used to determine if the destination is in the same subnet. The default value is "255.255.255.0".

"**Default router**" This is the gateway used to forward frames to destinations in different subnet. Invalid router setting will fail the transmission to destinations in different subnet.

"**Primary DNS**" The primary domain name server that translates hostnames into IP addresses.

"**Secondary DNS**" The secondary domain name server that backups the Primary DNS.

HTTP

“HTTP port” This can be other than the default Port 80. Once the port is changed, the User must be notified the change for the connection to be successful. For instance, when the Administrator changes the HTTP port of the Network Camera whose IP address is 192.168.0.100 from 80 to 8080, the User must type in the web browser “http://192.168.0.100:8080” instead of “http://192.168.0.100”.

Streaming

“UDP audio channel port” This can be something other than the default port 5002 in order to work with the port opened by the firewall.

“UDP video channel port” This can be something other than the default port 5003 in order to work with the port opened by the firewall.

The screenshot displays the 'Configuration' page for a network camera, specifically the 'Network' section. The interface includes a sidebar with navigation options and a main content area with configuration fields.

Configuration

> Network

Get IP address automatically
 Use fixed IP address

General

IP address	<input type="text" value="192.168.1.114"/>
Subnet mask	<input type="text" value="255.255.255.0"/>
Default router	<input type="text" value="192.168.1.1"/>
Primary DNS	<input type="text" value="0.0.0.0"/>
Secondary DNS	<input type="text" value="0.0.0.0"/>

HTTP

HTTP port	<input type="text" value="80"/>
-----------	---------------------------------

Streaming

UDP audio channel port	<input type="text" value="5002"/>
UDP video channel port	<input type="text" value="5003"/>

Version : 0100a

Mail & FTP

SMTP

"1st SMTP (mail) server" The domain name or IP address of the external email server.

"1st SMTP account name" Granted account name on the email server.

"1st SMTP password" Granted password on the email server.

"1st recipient email address" The email address of recipients for snapshots or log file. Multiple recipients must be separated by semicolon, `;`.

"2nd SMTP (mail) server" The domain name or IP address of another email server once the previous server is unreachable.

"2nd SMTP account name" Granted account name on the backup SMTP server.

"2nd SMTP password" Granted password on the backup SMTP server.

"2nd recipient email address" The email address of recipients for the backup server.

"Sender email address" The return email address used in the event the mails fail to send out.

FTP

"Built-in FTP server port" This can be other than the default Port 21. The User can change this value from 1 to 65535. After the change, the external FTP client program must change the server port of connection accordingly.

"1st FTP server" The domain name or IP address of the external FTP server. The following user settings must be correctly configured for remote access.

"1st FTP server port" The port to access the external FTP server.

"1st FTP user name" Granted user name on the external FTP server.

"1st FTP password" Granted password on the external FTP server.

"1st FTP remote folder" Granted folder on the external FTP server. The string must conform to that of the external FTP server. Some FTP servers cannot

accept preceding slash symbol before the path without virtual path mapping. Refer to the instructions for the external FTP server for details. The folder privilege must be open for upload.

"1st FTP passive mode" The Network Camera is located inside the network protected by a firewall, data connection for FTP may be prohibited. By selecting passive mode, the FTP can bypass the rule and allow snapshot upload to proceed. If the passive mode is selected, the Network Camera can automatically attempt for active mode, if the external FTP server does not support passive mode.

"2nd FTP server" The domain name or IP address of the backup FTP server.

"2nd FTP server port" The port to access the backup FTP server.

"2nd FTP user name" Granted user name on the backup FTP server.

"2nd FTP password" Granted password on the backup FTP server.

"2nd FTP remote folder" Granted folder on the backup FTP server.

"2nd FTP passive mode" Passive mode setting for the backup FTP server.

Video Codec Parameters

"Text on video" The text will be displayed in the black bar above the video window with a timestamp. The timestamp is captured from date and time of the Network Camera that is maintained by a built-in real-time clock.

"Color" Select either for color or monochrome video display.

"Size" There are five options for three video sizes. "Half" is the quarter size of "Normal" and "Normal" is the quarter size of "Double". "Half x 2" has the same video size as "Normal" but of a lesser quality, while consuming less network bandwidth. "Normal x 2" has the same size as "Double" but of a lesser quality.

"Video codec type" It can be either MJPEG or MPEG4. In MJPEG mode, the video frames are independent. In MPEG4 mode, there are I frames and P frames. To decode a P frame need the information of previous frame. MPEG4 consumes much less network bandwidth than MJPEG.

There are five dependent parameters provided for video performance adjustment. **"Maximum frame rate"** This limits the maximal refresh frame rate, which can be combined with the **"Video quality control"** to optimize the bandwidth utilization and video quality. If the User wants to fix the bandwidth utilization regardless of the video quality, choose **"Fix bit rate"** and select the desired bandwidth. MPEG4 video are composed by I frames and P frames as the following sequence. IPPPPPISPPPPISPPPP.. **"Key frame interval"** determines how many repeated P frames will appear after one I frame. Large **"Key frame interval"** can reduce the bit rate, but cause image corrupt longer if there is packet loss while transmission. **"Fix bit rate"** option and **"Key frame interval"** option are only available in **"MPEG4"** mode. The video quality may be poor due to the sending of maximal frame rate within the limited bandwidth when images are moving rapidly. Consequently, to ensure detailed video quality (quantization rate) regardless of the network, it will utilize more bandwidth to send the maximal frames when images change drastically.

"Flip" Vertically rotate the video.

"Mirror" Horizontally rotate the video. Check options both if the Network Camera is installed upside down.

"Improve efficiency in the multi-user environment" Check this option to

improve efficiency in the multi-user environment when running in the low bandwidth environment. But it will cause each connection slow a few minutes when connection established.

“Time stamp on video” When selected the time stamp format is:

- a) “Size” becomes Normal or Double, “Text on video hh:mm:ss yyyy/mm/dd”
- b) “Size” becomes half, “hh:mm:ss yyyy/mm/dd”

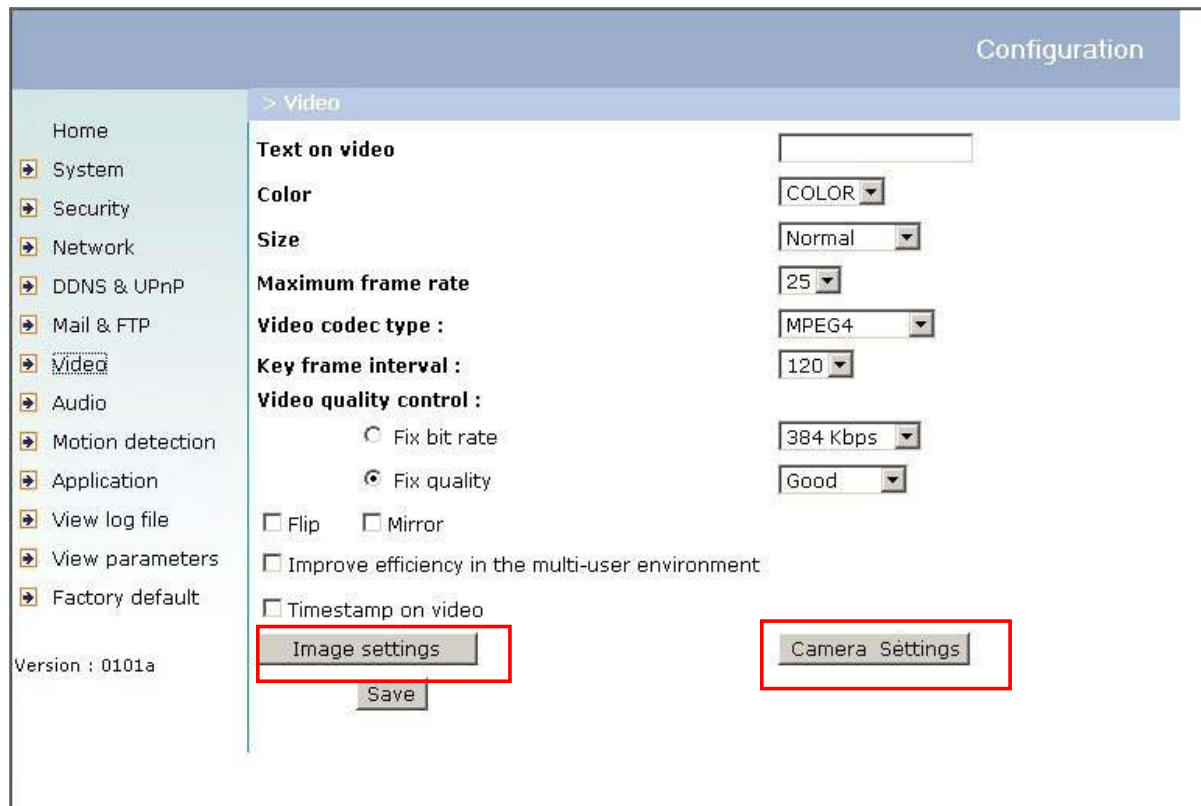

Image Settings

Click on "**Image Settings**" to pop up another window for tuning "**Brightness**", "**Contrast**", "**Hue**" and "**Saturation**" for video compensation.



Each field has eleven levels ranged from -5 to +5. The User may press "**Preview**" to fine-tune the image. When the image is O.K., press "**Save**" to set the image settings. Click on "**Restore**" to recall the original settings without incorporating the changes.

Camera Settings

Click on "**Camera Settings**" button, the Camera settings window will pop up.



"AES" - auto electronic shutter, enable this will let CCD sensor adjust electronic shutter automatically.

"BLC" - back light compensation, enable this will help to identify

"Flickless" - enable this to fix the electronic shutter to (1/100 NTSC)(1/120 PAL).

In the Camera Settings window, click on "**Preview**" to see the effect of changing the options. Click on "**Save**" to set the Camera Settings. Click on "**Restore**" to recall the original settings without incorporating the changes.

Motion Detection

“Enable motion detection” Check this option to turn on motion detection.

New Click on this button to add a new window. At most three windows can exist simultaneously. Use the mouse to click, hold and drag the window frame to resize or the title bar to move. Clicking on the ‘x’ at the upper right-hand corner of the window to delete the window. Remember to save in order to validate the changes.

Save Click on this button to save the related settings. A graphic bar will rise or fall depending on the image variations. A green bar means the image variation is under monitoring level and a red bar means the image variation is over monitoring level. When the bar goes red, the detected window will also be outlined in red. Going back to the homepage, the monitored window is hidden but the red frame shows when motion is detected.

“Window Name” The text will show at the top of the window.

“Sensitivity” This sets the endurable difference between two sequential images.

“Percentage” This sets the space ratio of moving objects in the monitoring window. Higher sensitivity and small percentage will allow easier motion detection.

Home

- System
- Security
- Network
- DDNS & UPnP
- Mail & FTP
- Video
- Audio
- Motion detection**
- Application
- View log file
- View parameters
- Factory default

Version : 0101a

> Motion detection

Enable motion detection

2004/11/03 17:32:20



Window Name:
Private Sky

Sensitivity:
47%

Percentage:
14%

New Save

Viewing System Log

Click on the link on the configuration page to view the system log file. The content of the file provides useful information about configuration and connections after system boot-up.

Viewing System Parameters

Click on this link on the configuration page to view the entire system's parameter set. The content is the same as those in CONFIG.INI.

Factory Default

"Factory default"

Click on this link on the configuration page to restore factory default settings. Any changes made so far will be lost and the system will be reset to the initial factory settings. After clicking on the "Restore" button and make confirmation, the system will restart and require the installer program to set up the network again.

Appendix

A. Troubleshooting

Status LED

After powering up, the Network Camera performs a self-diagnostic to detect any hardware defects. The following table lists the LED patterns in general. In case of any fatal error, the LED will blink in a pattern other than those below.

Condition	LED color
During self-diagnostic after power on	Blinking in interchanged Green and Red
After power on and before network is setup	Red LED is constantly ON and Green LED is OFF
After network is setup	Red LED is constantly ON and Green LED blinking every 0.5 second
Ethernet signal is lost	Red LED is constantly ON and Green LED is OFF
No audio or speak only	Red LED is constantly ON and Green LED blinking every second

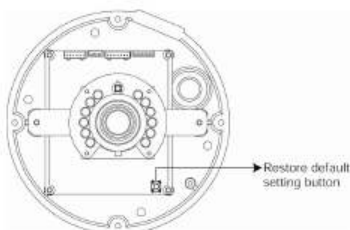

 Restoring the factory defaults will erase any previous settings. Reset or restore the system after power on.

Reset and Restore

There is a button on the main board of the camera inside the dome body as shown in the picture. It is used to reset the system or restore the factory default settings. Sometimes resetting the system sets the system back to normal state. If the system problems remain after reset, restore the factory settings and install again.

RESET: Press the button once.

RESTORE: 1. Press the button continuously.

2. Plug in the power and wait for the self-diagnostic. to run twice.

3. Release the button after both LEDs shut off. as soon as the second self-diagnostic starts..

D. Technical Specifications

- Networking

Protocol

TCP/IP, HTTP, SMTP, FTP, Telnet, NTP, DNS UPnP, DDNS and DHCP

Physical

10BaseT Ethernet or 100BaseT Fast Ethernet
Auto negotiation

- Video

Algorithm supported

MPEG4 simple profile/MJPEG selectable
JPEG for still image

Resolution

Up to 30/25 frames at 176x120 or 176x144
Up to 30/25 frames at 352x240 or 352x288
Up to 15/12 frames at 704x480 or 704x576

- Camera specification

1/3 inch color CCD sensor
0 Lux when IR on; IR distance: 10M
AGC, AWB, AES, Flickless
Electronic shutter: 1/60(1/50) to 1/100,000 sec

- Lens

F2.0, f=3.6mm

- General I/O

1 sensor input max. 12VDC 50mA
1 relay output max. 24VDC 1A, 125VAC 0.5A

- LED indicator

System power and status indicator
System activity and Network link indicator

- Weight

NET. 1070g

- Dimension

137 mm(D) * 110mm(H)

- Power

Consumption: MAX 7.2 W
Adapter input: 100-240VAC, 50/60Hz, 0.4A
Adapter output: 12VDC, 1.5A

- Operating Environment

Temperature: 0-50°C/32-122°F
Humidity: 95%RH

-EMI & Safety

CE, FCC, LVD

